

# AMERICAN LEATHER® CLASSICS COLLECTION

---

## ASTORIA



**AMERICAN  
LEATHER®**

**ASTORIA**

**Standard Features:**

- Advanced unidirectional suspension system
- Premium high-density, high-resiliency foam seats
- Quick-ship delivery
- Lifetime warranty on frame & suspension
- Loose back & seat cushions
- Buttonless tufting seat cushions
- Double needle top stitch using thick thread

**Options:**

- Wood legs available in Acorn, Espresso or Walnut finish

*Please use actual leather, fabric and Ultrasuede® swatches when specifying furniture as the colors shown may vary due to the printing process.*

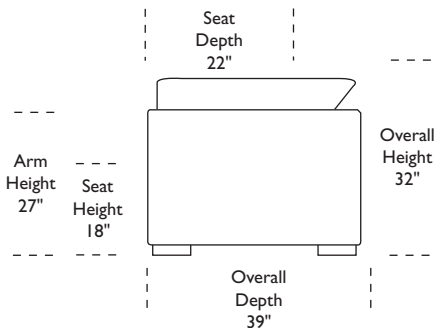
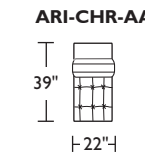
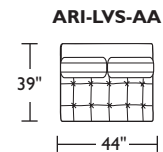
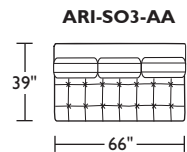
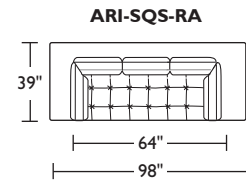
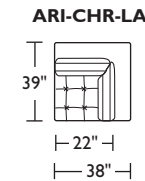
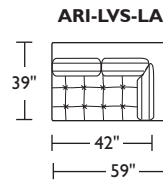
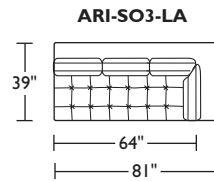
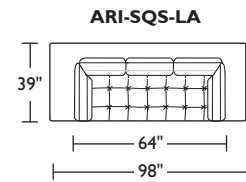
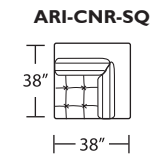
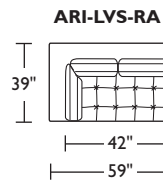
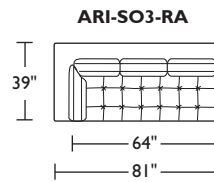
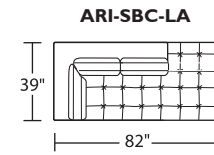
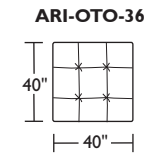
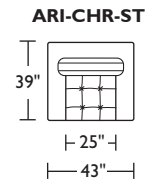
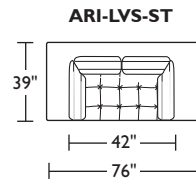
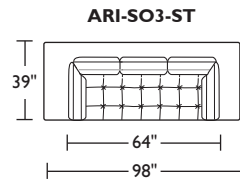
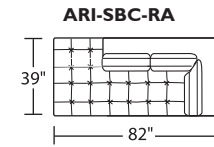
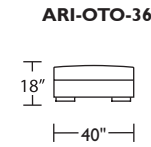
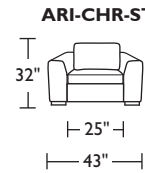
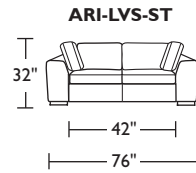
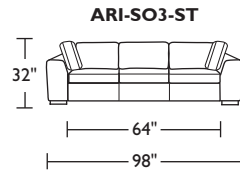

Scale: 1/8 inch = 1 foot  
 All dimensions are approximate and subject to change.  
 Specify components from the sitting position.